

INSTRUCTION MANUAL

IMPORTANT SAFEGUARDS

When using electrical equipment, basic safety precautions should always be followed, including the following:

READ AND FOLLOW ALL SAFETY INSTRUCTIONS

1. **CAUTION** - To prevent electrical shock, do not mate unit connector until installation is complete and A.C. power is supplied to the unit.
2. **CAUTION** - This kit provides more than one power supply output source. To reduce the risk of electrical shock, disconnect both the normal and back-up sources by turning off the A.C. branch circuit and by disconnecting the unit connector.
3. **CAUTION** - This is a sealed unit. Components are not replaceable. Replace the entire unit when necessary.
4. **CAUTION** - Installation and servicing should be performed by **qualified personnel only**. De-energize before opening.
5. The battery back up kit is for use with the T-BAR FLEX®, T-BAR ECO®, Gemini™, TERALyte™, T-BAR UP®, T-BAR STAX™ and T-BAR LED® X-Series only (fixture sold separately). Not for use in heated air outlets or hazardous locations.
6. The battery back up kit requires an unswitched A.C. power source of 120 to 277 volts AC, 50/60Hz.
7. The **battery** and **LED Driver** A.C. power **must** be on the same branch circuit.
8. Do not mount near gas or electric heaters.
9. The battery back up kit should be mounted in locations and at heights where it will not readily be subjected to tampering by unauthorized personnel.
10. The battery back up kit will supply 10-60VDC output at the individual rated specification for 90 minutes. See individual units for output specifications.
11. Suitable for use in damp locations and plenum spaces.
12. For use in 0° C minimum, 55° C maximum ambient temperatures.
13. The use of accessory equipment not recommended by the manufacturer may cause an unsafe condition, void warranty, and result in non-compliance with UL specifications.
14. Do not use this equipment for other than intended use.

SAVE THESE INSTRUCTIONS



EMERGENCY LED DRIVER FOR USE
WITH LED LUMINAIRES IDENTIFIED IN
THE MANUFACTURER'S INSTALLATION
INSTRUCTIONS
E473237
CLASS 2 OUTPUT



THIS UNIT CONTAINS A
RECHARGEABLE NICKEL-CADMIUM BATTERY.
PLEASE RECYCLE OR DISPOSE OF PROPERLY.

INSTALLATION INSTRUCTIONS

CAUTION: Before installing, make certain the A.C. power is off and the battery unit connector is disconnected.

1. FIXTURE AND BATTERY INSTALLATION

The battery backup kit is designed to be used with the T-BAR FLEX, T-BAR ECO, Gemini, TERALyte, T-BAR UP, T-BAR STAX or T-BAR LED X-Series product lines only (fixture sold separately). See the technical specification sheet for output specifications and lumen output information for the battery back up kit. Refer to the last page for mechanical installation of the battery kit.

2. A.C. INPUT WIRING

Refer to the below diagram for the appropriate wiring of battery and LED fixture. Install in accordance with National Electrical Code and local regulations.

A. The battery and LED fixture **MUST** be on the same branch circuit.

B. The battery requires an **unswitched** A.C. power source of 120-277 VAC, 50/60Hz; therefore when used with switched fixtures, the battery input must be wired ahead of the switch.

C. Refer to the wiring diagram for the proper wiring.

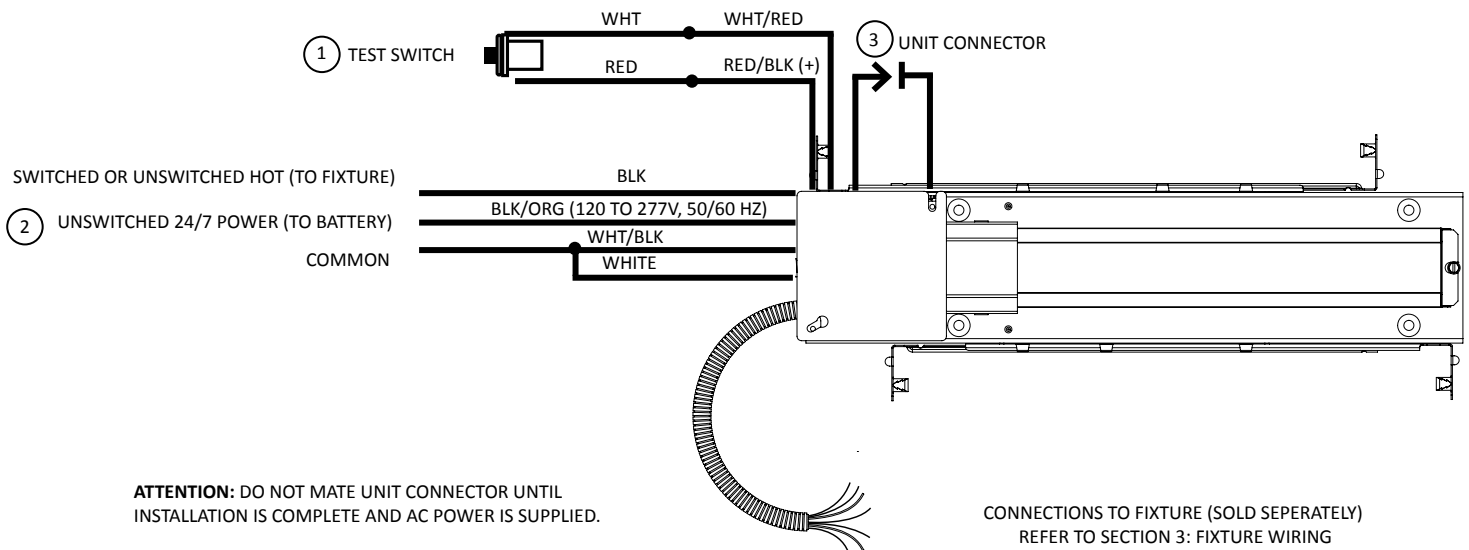

ATTENTION: DO NOT MATE UNIT CONNECTOR UNTIL INSTALLATION IS COMPLETE AND AC POWER IS SUPPLIED.

- ① TEST ACCESSORY LEADS - OBSERVE PROPER POLARITY WIRING.
- ② CONNECT UNSWITCHED POWER. IF A SINGLE BUILDING COMMON IS PRESENT, CONNECT THE WHITE WIRE TO THE COMMON. IF A SEPARATE UNSWITCHED CONDUCTOR FEED IS PRESENT, CONNECT THE WHITE LEAD TO THE COMMON FROM THE UNSWITCHED FEED.
- ③ MATE UNIT CONNECTOR AFTER INSTALLATION IS COMPLETE AND AC POWER IS SUPPLIED

CONNECTIONS TO FIXTURE (SOLD SEPARATELY)
REFER TO SECTION 3: FIXTURE WIRING

3. FIXTURE WIRING

The battery backup kit is designed to be used with the T-BAR FLEX, T-BAR ECO, GEMINI, TERALyte, T-BAR UP*, T-BAR STAX or T-BAR LED X-Series product lines only (fixture sold separately). See the below illustration for wiring details.

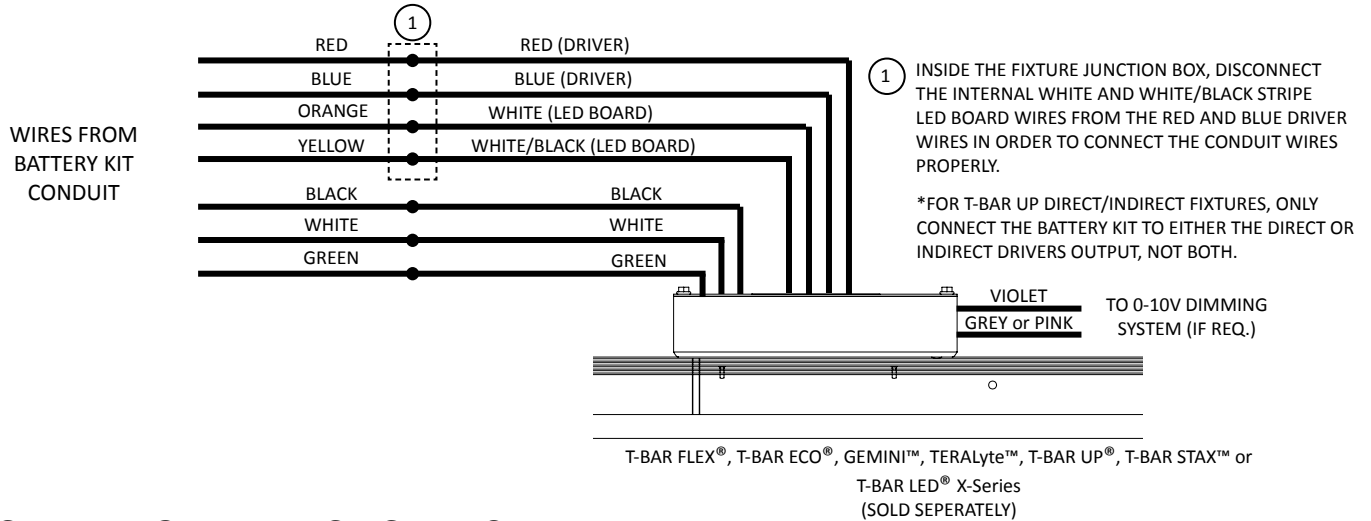

4. INSTALLING THE TEST SWITCH

Select a convenient location so that the test switch can be seen after installation. Wire the test switch to the kit using conduit and a junction box (not provided). Drill a 1/2" hole in the junction box faceplate (not provided). Push the test switch into the faceplate and secure with the nut. Connect the wires from the battery kit to the test switch (Black/Red to Red, and White/Red to White). For proper operation, use only the accessory components provided with the unit.

5. LABELS

Attach the provided label on the faceplate cover adjacent to the test switch.

6. COMPLETING INSTALLATION

When the installation is complete, switch the A.C. power on and join the battery unit connector.

OPERATION

Normal Mode - A.C. power is present, the LED driver operates the LED load as intended. The battery is in the standby charging mode. The test switch will be lit providing a visual indication that the battery is being charged.

Back Up Mode - The A.C. power fails. The battery senses the A.C. power failure and automatically switches to the *Back Up Mode*. The fixture will illuminate for a minimum of 90 minutes. When the A.C. power is restored, the battery switches the system back to the *Normal Mode* and resumes battery charging.

TESTING & MAINTENANCE

Pressing the test switch turns off the light on the switch and forces the unit into back up mode, interrupting power to the designated LED driver. The LED load is now being lit by the battery unit. After releasing the test switch, the fixture returns to normal operation after a momentary delay. To simulate a “BLACK OUT” use the circuit breaker to turn off A.C. power.

Initial Testing - Allow the unit to charge approximately 1 hour, then conduct a short discharge test. Allow a 24 hour charge before conducting a one hour test.

The battery is a maintenance free unit, however, periodic inspection and testing is required. NFPA 101, Life Safety Code, outlines the following schedule:

Monthly - Ensure that the test switch light is illuminated. Conduct a 30 second discharge test by depressing the test switch. The fixture should operate at reduced output.

Annually - Ensure that the test switch light is illuminated. Conduct a full 90 minute discharge test. The unit should operate as intended for the duration of the test.

“Written records of testing shall be kept by the owner for inspection by the authority having jurisdiction”

SERVICING SHOULD BE PERFORMED BY QUALIFIED PERSONNEL

MECHANICAL INSTALLATION

The battery backup kit is designed to be installed in close proximity to the compatible fixture by either of the below grid ceiling mounting or surface mounting methods:

Grid Ceiling Mounting

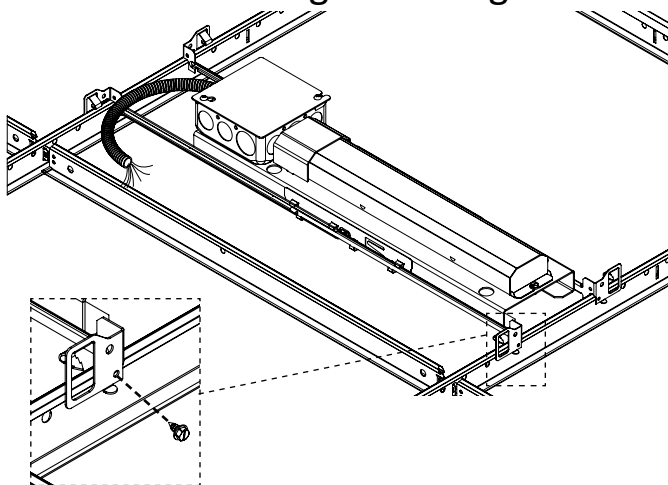

Adjust the T-BAR brackets to fit over the grid, secure each bracket to the grid with a sheet metal screw (not provided)

Surface Mounting

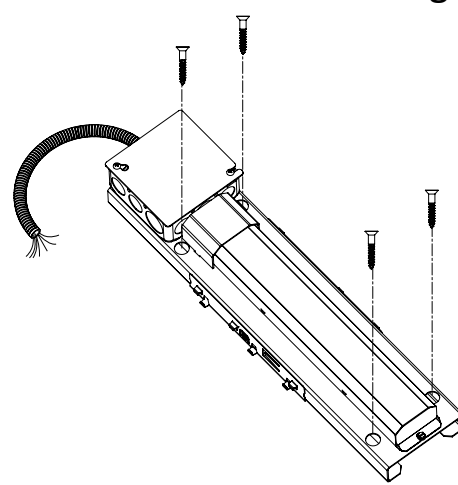

Use the (4) mounting holes with an appropriate screw (not provided) for the specific mounting application.