

PO number: _____ Signature: _____

T-BAR LED EM Battery & Driver Kit | Order Specification Guide



Product Name	Driver Type	Battery	Wattage	Voltage
TBEM = T-BAR LED EM Battery/Driver Kit	PS = Non Dimmable DIM = 1% Dimmable 0-10 VDC	12 = 12W Battery	64 = 64W Driver	UNV = Universal 120-277V

WARRANTY: 5 years

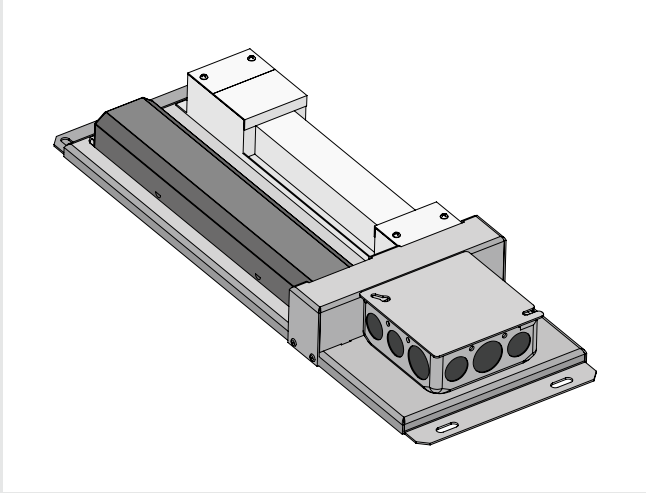

T-BAR LED® EM Battery & Driver Kit

24VDC 64W LED Driver with 12W Battery Kit
0-10 VDC dimmable and non dimmable

Factory wired battery backup and LED driver for remote installation allows the same T-BAR LED to be used for both normal and emergency operation. In emergency mode the kit provides 12W of power for 90 minutes. Available with 0-10Vdc nominal 1% dimming during non-emergency mode.

Power kit includes 4" JB for 120-277V AC input direct wiring with metal conduit and single-piece charge indicator and test switch accessory.

T-BAR LED EM Battery & Driver Kit is compatible with the following product range: T-BAR LED®, T-BAR UP®, T-BAR TWO®, T-BAR ECO® DC, Sorella™.

24VDC 64W LED Driver and 12W Battery

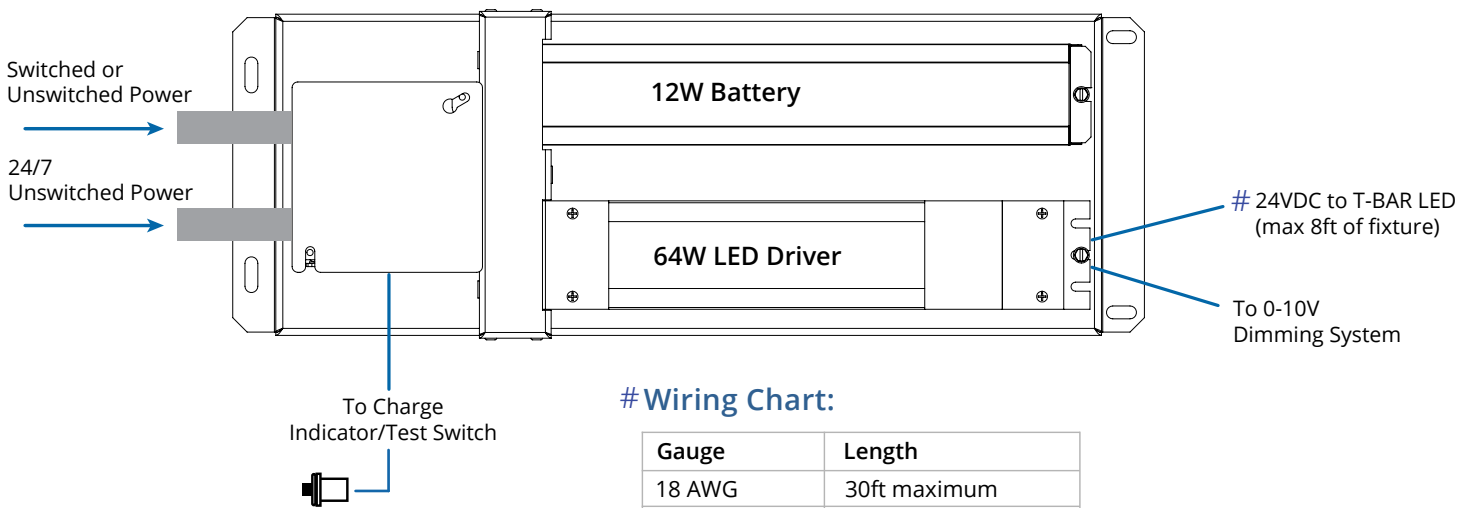
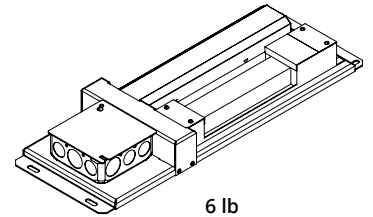
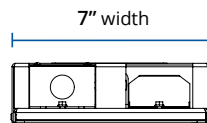
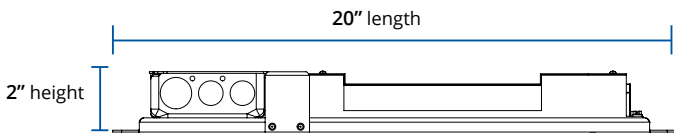

Wiring Chart:

Gauge	Length
18 AWG	30ft maximum
16 AWG	40ft maximum
14 AWG	50ft maximum

* Refer to spec sheet and installation instruction for technical specifications and detailed wiring diagram.